

# V. REQUIREMENTS FOR TRANSFORMERS SITUATED ON CUSTOMER PROPERTY

## FIGURE V-1

### PROTECTIVE BARRIER AND PLANTING CLEARANCES FOR PADMOUNTED TRANSFORMERS AND SWITCHES

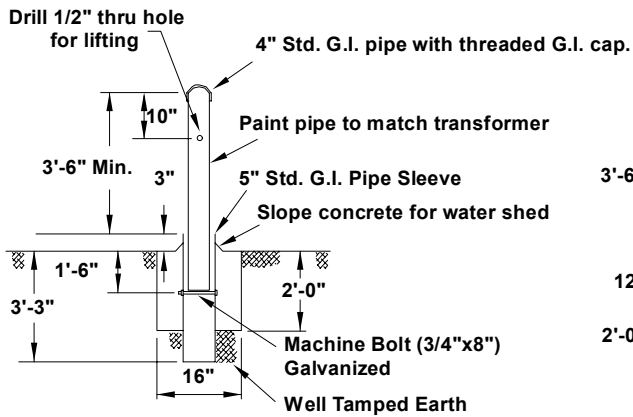
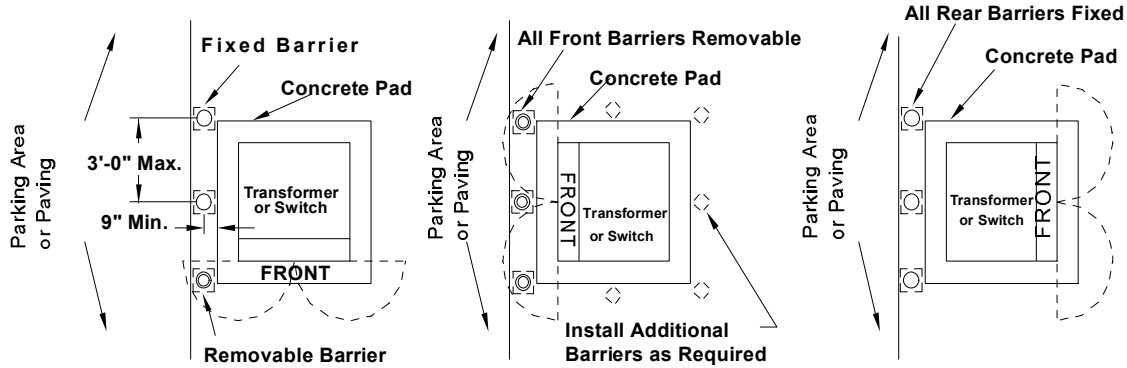

**REMOVABLE BARRIER**

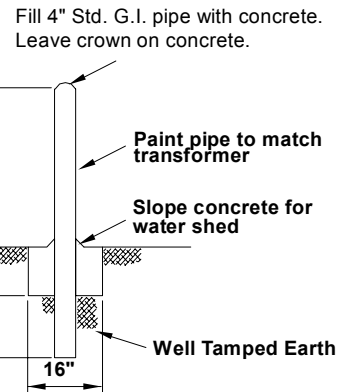

**REMOVABLE BARRIER**

